

Fenner®



Fenner® QD:E



**Installation
and
Operating
Instructions**



Declaration of Conformity:

ERIKS Industrial Services Ltd hereby states that the Fenner QD:E Series product range is CE marked for the low voltage directive and conforms to the following harmonised European directives:

EN 61800-5-1: 2003	Adjustable speed electrical power drive systems. Safety requirements. Electrical, thermal and energy.
EN 61800-3 2nd Ed: 2004	Adjustable speed electrical power drive systems. EMC requirements and specific test methods
EN 55011: 2007	Limits and Methods of measurement of radio disturbance characteristics of industrial, scientific and medical (ISM) radio-frequency equipment (EMC)

All rights reserved. No part of this User Guide may be reproduced or transmitted in any form or by any means, electrical or mechanical including photocopying, recording or by any information storage or retrieval system without permission in writing from the publisher.

Copyright ERIKS Industrial Services Ltd ©•2008

The manufacturer accepts no liability for any consequences resulting from inappropriate, negligent or incorrect installation, or adjustment of the optional operating parameters of the drive or from mismatching of the drive to the motor.

The contents of this User Guide are believed to be correct at the time of printing. In the interest of a commitment to a policy of continuous improvement, the manufacturer reserves the right to change the specification of the product or its performance or the contents of the User Guide without notice.

All Fenner QD Series products carry a 2-year warranty, valid from the date of manufacture. This date is clearly visible on the product rating label.

This User Guide is for use with V1.02 Software.
User Guide Issue 1.01

Company Information

Address: ERIKS Industrial Services Ltd
Amber Way
Halesowen
West Midlands
B62 8WG

Email: sales@ftpgroup.com
Website: www.ftpgroup.com

1. INTRODUCTION	4	7. PARAMETERS	11
1.1. Important safety information	4	7.1. Standard parameters	11
1.2. Electromagnetic Compatibility (EMC)	4	7.2. Extended parameters	12
2. GENERAL INFORMATION AND RATINGS	5	7.2.1. Parameter group zero access and navigation	14
2.1. Identifying the drive by model number	5	8. ANALOG AND DIGITAL INPUT CONFIGURATIONS	15
2.2. Drive model numbers	5	8.1. Terminal mode (P-12 =0)	15
3. MECHANICAL INSTALLATION	6	8.2. Keypad mode (P-12 = 1 or 2)	16
3.1. General	6	8.3. MODBUS control mode (P12 = 3 or 4)	17
3.2. Mechanical dimensions and mounting	6	8.4. User PI control mode (P-12 = 5 or 6)	17
3.3. Enclosure Mounting	6	9. TROUBLESHOOTING	18
4. POWER WIRING	7	9.1. Fault messages	18
4.1. Grounding the Drive	7	10. TECHNICAL DATA	18
4.1.1. Grounding Guidelines	7	10.1. Environmental Data	18
4.2. Wiring Precautions	7	10.2. Rating tables	19
4.3. Connection Diagrams	8	10.3. Maximum supply ratings for UL compliance:	19
4.4. Drive and motor connections	8	Fenner QD:E Easy Start Up Guide	20
4.5. Motor Terminal Box Connections	8		
5. CONTROL WIRING	9		
5.1. Control terminal connections	9		
5.2. RJ45 Data Connection	9		
6. OPERATION	9		
6.1. Managing the keypad	9		
6.1.1. Changing Parameters	10		
6.1.2. Reset Factory Default Settings	10		
6.2. Terminal Control	10		
6.3. Keypad Control	10		

NOTE

ERIKS reserves the right to modify the characteristics of its products at any time in order to incorporate technological developments. The information contained in this document may therefore be changed without notice.

1. INTRODUCTION

1.1. IMPORTANT SAFETY INFORMATION

This variable speed drive product (Fenner QD Series) is intended for professional incorporation into complete equipment or systems. If installed incorrectly it may present a safety hazard. The Fenner drive uses high voltages and currents, carries a high level of stored electrical energy, and is used to control mechanical plant that may cause injury. Close attention is required to system design and electrical installation to avoid hazards in either normal operation or in the event of equipment malfunction.

System design, installation, commissioning and maintenance must be carried out only by personnel who have the necessary training and experience. They must carefully read this safety information and the instructions in this Guide and follow all information regarding transport, storage, installation and use of the Fenner drive, including the specified environmental limitations.

Please read the IMPORTANT SAFETY INFORMATION below, and all Warning and Caution information elsewhere.



Indicates a potentially hazardous situation which, if not avoided, could result in injury or death.



Indicates a potentially hazardous situation which, if not avoided, could result in damage to property.

Safety of machinery, and safety-critical applications

The level of integrity offered by the Fenner drives control functions – for example stop/start, forward/reverse and maximum speed, is not sufficient for use in safety-critical applications without independent channels of protection. All applications where malfunction could cause injury or loss of life must be subject to a risk assessment and further protection provided where needed. Within the European Union, all machinery in which this product is used must comply with Directive 89/392/EEC, Safety of Machinery. In particular, the electrical equipment should comply with EN60204-1.



- Fenner drives should be installed only by qualified electrical persons and in accordance with local and national regulations and codes of practice. The Fenner drives has an Ingress Protection rating of IP55. For higher IP ratings, use a suitable enclosure.
- Electric shock hazard! Disconnect and ISOLATE the Fenner drives before attempting any work on it. High voltages are present at the terminals and within the drive for up to 10 minutes after disconnection of the electrical supply.
- Where supply to the drive is through a plug and socket connector, do not disconnect until 10 minutes have elapsed after turning off the supply
- Ensure correct earthing connections. The earth cable must be sufficient to carry the maximum supply fault current which normally will be limited by the fuses or MCB
- The STOP function does not remove potentially lethal high voltages. ISOLATE the drive and wait 10 minutes before starting any work on it
- Parameter P-01 can be set to operate the motor at up to 60,000 rpm, hence use this parameter with care.
- If it is desired to operate the drive at any frequency/speed above the rated speed (P-09/ P-10) of the motor, consult the manufacturers of the motor and the driven machine about suitability for over-speed operation.



- The fan (if fitted) inside of the Fenner drive starts automatically when the heatsink temperature reaches approximately 45°C.
- Carefully inspect the Fenner drive before installation to ensure it is undamaged
- Indoor Use Only.
- Flammable material should not be placed close to the drive
- The entry of conductive or flammable foreign bodies should be prevented
- Relative humidity must be less than 95% (non-condensing).
- Ensure that the supply voltage, frequency and no. of phases (1 or 3 phase) correspond to the rating of the Fenner drive as delivered.
- An isolator should be installed between the power supply and the drive.
- Never connect the mains power supply to the Output terminals U, V, W.
- Suitably rated fuses or MCB should be fitted in the mains supply to the drive
- Do not install any type of automatic switchgear between the drive and the motor
- Wherever control cabling is close to power cabling, maintain a minimum separation of 100 mm and arrange crossings at 90 degrees
- Integral solid state short circuit protection does not provide branch circuit protection. Branch circuit protection must be provided in accordance with the National Electrical Code and any additional local codes

1.2. ELECTROMAGNETIC COMPATIBILITY (EMC)

Fenner drive is designed to high standards of EMC and is fitted with an internal EMC filter. This EMC filter is designed to reduce the conducted emissions back into the supply via the power cables for compliance with harmonised European standards. It is the responsibility of the installer to ensure that the equipment or system into which the product is incorporated complies with the EMC legislation of the country of use. Within the European Union, equipment into which this product is incorporated must comply with 89/336/EEC, EMC.

For use on domestic supplies, screened motor cable must be used with the screen terminated to earth on both motor and drive sides. The installation must be carried out by qualified installation engineers, observing good wiring practice such as power and signal cable segregation and correct screening techniques to minimise emissions. When installed in this way, the Fenner drive with built-in filter has emission levels lower than those defined in EN61800-3 category C2 for 1st environments (domestic) for screened cable lengths of up to 5m.

For cable lengths above 5m, the emission levels may exceed those defined by EN61800-3 cat C2. In this case, further mitigation methods (such as fitting an external filter - QFilter) must be employed if the emissions limits for domestic supplies are to be upheld.

When used on industrial supplies, or 2nd environments, the installation must be carried out by qualified installation engineers, observing good wiring practice such as power and signal cable segregation and correct screening techniques to minimise emissions. The emissions limits defined by EN61800-3 cat C3 (2nd environment) are upheld for screened cable lengths of up to 25m. The cable screen should be connected to earth on both the drive and motor sides.

2. GENERAL INFORMATION AND RATINGS

This chapter contains information about the Fenner QD:E including how to identify the drive

2.1. IDENTIFYING THE DRIVE BY MODEL NUMBER

NUMBER

Each drive can be identified by its model number, as shown in Figure 1 Drive Model Number Format. The model number is on the shipping label and the drive nameplate. The model number includes the drive and any options. Drive model numbers for the Fenner QD:E drives are provided in 10.2 Rating tables.

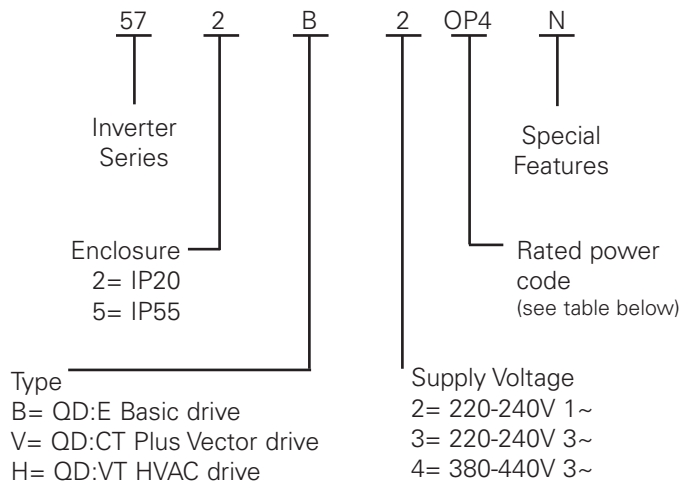

NOTE Refer to the table below.

FIGURE 1 DRIVE MODEL NUMBER FORMAT

2.2. DRIVE MODEL NUMBERS

200-240V ±10% - 1 Phase Input

kW Model Number With Filter	kW	HP	Output Current (A)	Frame Size
572B20P4	0.37	0.5	2.3	1
572B20P7	0.75	1	4.3	1
572B21P5	1.5	2	7	1
572B21P5E	1.5	2	7	2
572B22P2	2.2	3	10.5	2

200-240V ±10% - 3 Phase Input

kW Model Number With Filter	kW	HP	Output Current (A)	Frame Size
	0.37	0.5	2.3	1
	0.75	1	4.3	1
	1.5	2	7	1
572B31P5E	1.5	2	7	2
572B32P2	2.2	3	10.5	2
572B34P0	4.0	5	8	3

380-480V ±10% - 3 Phase Input

kW Model Number With Filter	kW	HP	Output Current (A)	Frame Size
572B40P7	0.75	1	2.2	1
572B41P5	1.5	2	4.1	1
572B41PE	1.5	2	4.1	2
572B42P2	2.2	3	5.8	2
572B44P0	4	5	9.5	2
572B45P5	5.5	7.5	14	3
572B47P5	7.5	10	18	3
572B4011	11	15	24	3

3. MECHANICAL INSTALLATION

3.1. GENERAL

- Store the Fenner QD:E drive in its box until required. Storage should be clean and dry and within the temperature range -40°C to +60°C
- Install the Fenner drive on a flat, vertical, flame-resistant, vibration-free mounting within a suitable enclosure, according to EN60529 if specific Ingress Protection ratings are required
- The drive must be installed in a pollution degree 1 or 2 environment
- Sizes 1 & 2 are DIN rail mountable, Size 3 is not DIN rail mountable.
- Ensure that all terminals are tightened to the appropriate torque setting

3.2. MECHANICAL DIMENSIONS AND MOUNTING

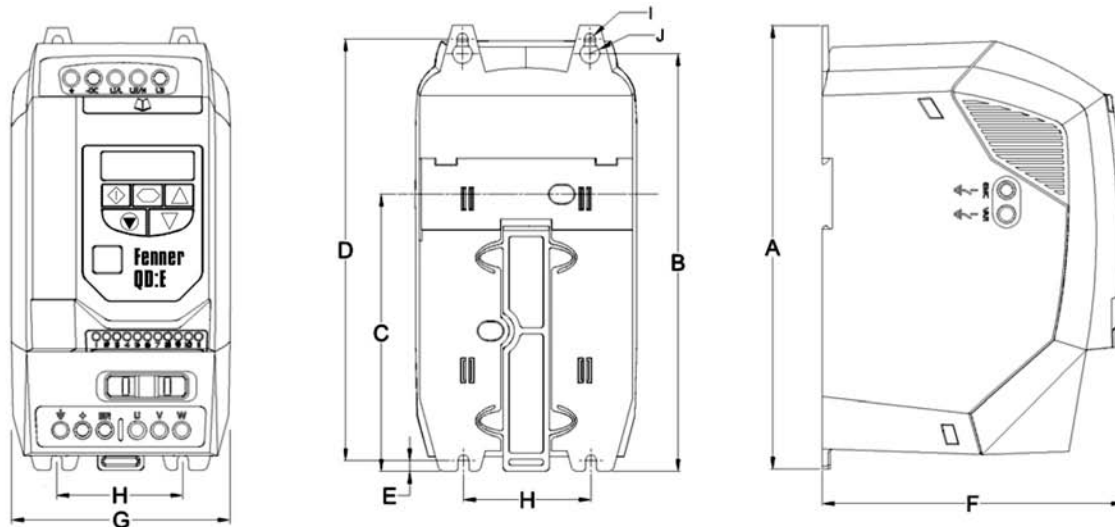

Drive Size	A		B		C		D		E		F		G		H		I		J	
	mm	in	mm	in	mm	in	mm	in	mm	in	mm	in	mm	in	mm	in	mm	in	mm	in
1	200	7.87	166	6.54	-	-	141	5.55	33	1.30	162	6.38	140	5.51	128	5.04	4.2	0.17	8.4	0.33
2	310	12.20	276	10.87	-	-	251	9.88	33	1.30	176	6.93	164	6.46	153	6.02	4.2	0.17	8.4	0.33
3	310	12.20	276	10.87	-	-	251	9.88	33	1.30	228	8.98	210.5	8.29	197.5	7.78	4.2	0.17	8.4	0.33

Control Terminal Torque Settings of 0.5 Nm (4.5 lb-in)

Power Terminal Torque Settings of 1 Nm (9 lb-in)

3.3. ENCLOSURE MOUNTING

For applications that require a higher IP rating than the IP20 offered by the standard drive, the drive must be mounted in a metallic enclosure. The following guidelines should be observed for these applications:

- Enclosures should be made from a thermally conductive material.
- When vented enclosures are used, there should be venting above the drive and below the drive to ensure good air circulation. Air should be drawn in below the drive and expelled above the drive.
- If the external environment contains contamination particles (e.g. dust), a suitable particle filter should be fitted to the vents and forced ventilation implemented. The filter must be serviced / cleaned appropriately.
- High moisture, salt or chemical content environments should use a suitably sealed (non-vented) enclosure.

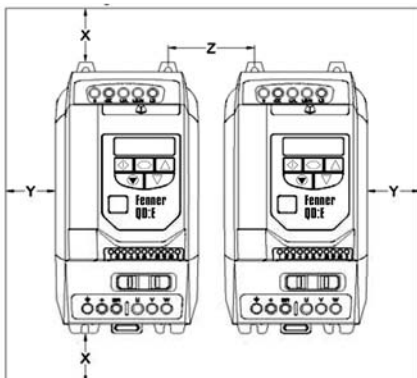

Drive Size	X Above/Below		Y Either Side		Z Between		Recommended airflow CFM (ft ³ /min)
	mm	in	mm	in	mm	in	
1	50	1.97	50	1.97	33	1.30	11
2	75	2.95	50	1.97	46	1.81	11
3	100	3.94	50	1.97	52	2.05	26

Note: Dimension Z assumes that the drives are mounted side-by-side with no clearance.

Typical drive heat losses are 3% of operating load conditions.

Above are guidelines only and the operating ambient temperature of the drive MUST be maintained at all times.

4. POWER WIRING

4.1. GROUNDING THE DRIVE



This manual is intended as a guide for proper installation. ERIKS Industrial Services Ltd cannot assume responsibility for the compliance or the non-compliance to any code, national, local or otherwise, for the proper installation of this drive or associated equipment. A hazard of personal injury and/or equipment exists if codes are ignored during installation.



This drive contains high voltage capacitors that take time to discharge after removal of main supply. Before working on the drive, ensure isolation of main supply from line inputs. Wait ten (10) minutes for capacitors to discharge to safe voltage levels. Failure to observe this precaution could result in severe bodily injury or loss of life.



Only qualified electrical personnel familiar with the construction and operation of this equipment and the hazards involved should install, adjust, operate, or service this equipment. Read and understand this manual and other applicable manuals in their entirety before proceeding. Failure to observe this precaution could result in severe bodily injury or loss of life.

NOTE Use the dedicated ground terminal to ground the drive. Do not use mounting screws/bolts or chassis screws for grounding

4.1.1. GROUNDING GUIDELINES

The ground terminal of each Fenner drive should be individually connected DIRECTLY to the site ground busbar. Fenner drive ground connections should not loop from one drive to another, or to, or from any other equipment. Ground loop impedance must confirm to local industrial safety regulations. To meet UL regulations, UL approved ring crimp terminals should be used for all ground wiring connections.

The drive Safety Ground must be connected to system ground. Ground impedance must conform to the requirements of national and local industrial safety regulations and/or electrical codes. The integrity of all ground connections should be checked periodically.

Ground Fault Monitoring

If a system ground fault monitor is to be used, only Type B devices should be used to avoid nuisance tripping.

Drives with an EMC filter have an inherently higher leakage current to Ground (Earth). For applications where tripping occurs the EMC filter can be disconnected by removing the EMC screw on the side of the product.

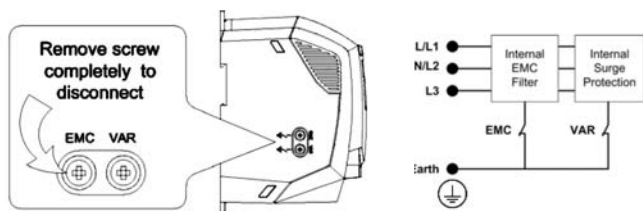

surge suppression components fitted to protect the drive from line voltage transients, typically originating from lightning strikes or switching of high power equipment on the same supply.

When carrying out a HiPot (Flash) test on an installation in which the drive is built, the voltage surge suppression components may cause the test to fail. To accommodate this type of system HiPot test, the voltage surge suppression components can be disconnected by removing the VAR screw. After completing the HiPot test, the screw should be replaced and the HiPot test repeated. The test should then fail, indicating that the voltage surge suppression components are once again in circuit.

Safety Ground

This is the safety ground for the drive that is required by code. One of these points must be connected to adjacent building steel (girder, joist), a floor ground rod, or bus bar. Grounding points must comply with national and local industrial safety regulations and/or electrical codes.

Motor Ground

The motor ground must be connected to one of the ground terminals on the drive.

Shield Termination (Cable Screen)

The safety ground terminal provides a grounding point for the motor cable shield. The motor cable shield connected to this terminal (drive end) should also be connected to the motor frame (motor end). Use a shield terminating or EMI clamp to connect the shield to the safety ground terminal. When shielded cable is used for control and signal wiring, the shield should be grounded at the source end only, not at the drive end.

4.2. WIRING PRECAUTIONS

Connect drive according to section 4.3 Connection Diagram, ensuring that motor terminal box connections are correct. There are two connections in general: Star and Delta. It is essential to ensure that the motor is connected in accordance with the voltage at which it will be operated. For more information, refer to section 4.5 Motor Terminal Box Connections. For recommended cabling and wiring sizing, refer to section 10.2 Rating tables. It is recommended that the power cabling should be 3-core or 4-core PVC-insulated screened cable, laid in accordance with local industrial regulations and codes of practice.

The Fenner QD product range has input supply voltage

4.3. CONNECTION DIAGRAM

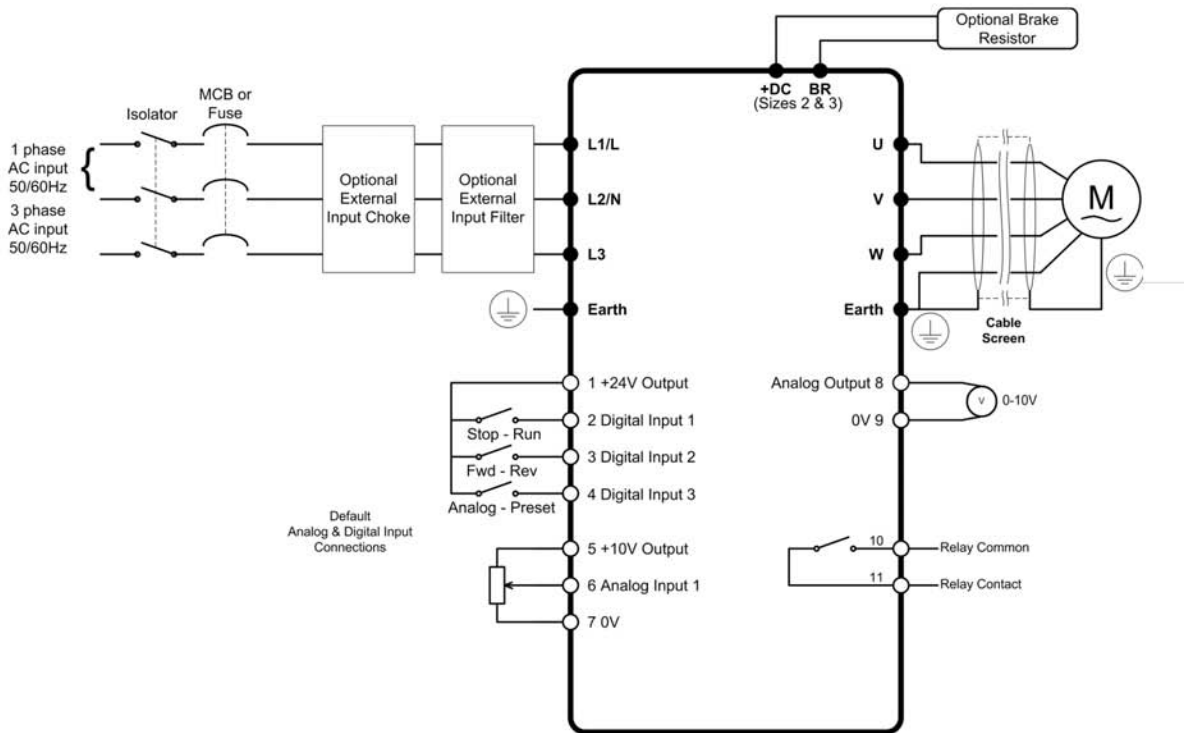

4.4. DRIVE AND MOTOR CONNECTIONS

For 1 phase supply power should be connected to L1/L, L2/N.

For 3 phase supplies power should be connected to L1, L2, L3. Phase sequence is not important.

The Motor should be connected to U, V, W

For drives that have a dynamic brake transistor an optional external braking resistor will need be connected to +DC and BR when required. The brake resistor circuit should be protected by a suitable thermal protection circuit. Further information can be found in the Advanced User Guide.

The -DC, +DC and BR connections are blanked off by plastic tabs when sent from the factory. The plastic tabs can be removed if/when required.

Size 1 Connections



Size 2 & 3 Connections



4.5. MOTOR TERMINAL BOX CONNECTIONS

Most general purpose motors are wound for operation on dual voltage supplies. This is indicated on the nameplate of the motor

This operational voltage is normally selected when installing the motor by selecting either STAR or DELTA connection. STAR always gives the higher of the two voltage ratings.

Typical ratings are:

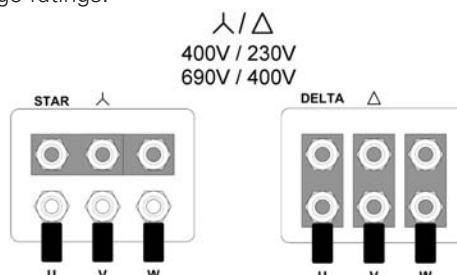

5.1. CONTROL TERMINAL CONNECTIONS

Default Connections	Control Terminal	Signal	Description
	1	+24V User Output,	+24V, 100mA.
	2	Digital Input 1	Positive logic "Logic 1" input voltage range: 8V ... 30V DC "Logic 0" input voltage range: 0V ... 4V DC
	3	Digital Input 2	
	4	Digital Input 3 / Analog Input 2	Digital: 8 to 30V Analog: 0 to 10V, 0 to 20mA or 4 to 20mA
	5	+10V User Output	+10V, 10mA, 1kΩ minimum
	6	Analog Input 1 / Digital Input 4	Analog: 0 to 10V, 0 to 20mA or 4 to 20mA Digital: 8 to 30V
	7	0V	User ground connected terminal 9
	8	Analog Output / Digital Output	Analog: 0 to 10V, 20mA maximum Digital: 0 to 24V
	9	0V	User ground connected terminal 7
	10	Relay Common	
	11	Relay NO Contact	Contact 250Vac, 6A / 30Vdc, 5A

5.2. RJ45 DATA CONNECTION

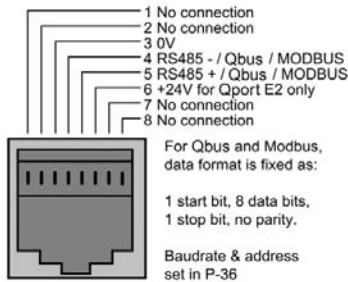

For MODBUS RTU register map information please refer to the Fenner QD:E Advanced User Guide.

When using MODBUS control the Analog and Digital Inputs can be configured as shown in section 8.3

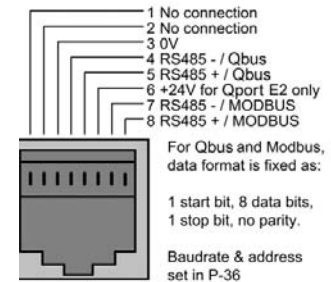

Operation







6. OPERATION

6.1. MANAGING THE KEYPAD





The drive is configured and its operation monitored via the keypad and display.

	NAVIGATE	Used to display real-time information, to access and exit parameter edit mode and to store parameter changes	
	UP	Used to increase speed in real-time mode or to increase parameter values in parameter edit mode	
	DOWN	Used to decrease speed in real-time mode or to decrease parameter values in parameter edit mode	
	RESET/ STOP	Used to reset a tripped drive. When in Keypad mode is used to Stop a running drive	
	START	When in keypad mode, used to Start a stopped drive or to reverse the direction of rotation if bi-directional keypad mode is enabled	

6.1.1. CHANGING PARAMETERS



To change a parameter value press and hold the  key for >1s whilst the drive displays STOP. The display changes to P-01, indicating parameter 01. Press and release the key  display the value of this parameter. Change to the required value using the  and  keys. Press and release the  key once more to store the change. Press and hold the  key for >1s to return to real-time mode. The display shows STOP if the drive is stopped or the real-time information (e.g. speed) if the drive is running.

6.1.2. RESET FACTORY DEFAULT SETTINGS

To reset factory default parameters, press ,  and  for >2s. The display shows P-dEF. Press the  button to acknowledge and reset the drive.

6.2. TERMINAL CONTROL



When delivered, the Fenner drive is in the factory default state, meaning that it is set to operate in terminal control mode and all parameters (P-xx) have the default values as indicated in section 7 Parameters.

1. Connect motor to drive, checking star/delta connection for the voltage rating
2. Enter motor data from motor nameplate, P-07 = motor rated voltage, P-08 = motor rated current, P-09 = motor rated frequency.
3. Connect a control switch between the control terminals 1 and 2 ensuring that the contact is open (drive disabled).
4. Connect a potentiometer (1k Ω min to 10 k Ω max) between terminals 5 and 7, and the wiper to terminal 6.
5. With the potentiometer set to zero, switch on the supply to the drive. The display will show STOP.
6. Close the control switch, terminals 1-2. The drive is now 'enabled' and the output frequency/speed are controlled by the potentiometer. The display shows zero speed in Hz (H 0.0) with the potentiometer turned to minimum.
7. Turn the potentiometer to maximum. The motor will accelerate to 50Hz (the default value of P-01) under the control of the accelerating ramp time P-03. The display shows 50Hz (H 50.0) at max speed.
8. To display motor current (A), briefly press the  (Navigate) key.
9. Press  again to return to speed display.
10. To stop the motor, either turn the potentiometer back to zero or disable the drive by opening the control switch (terminals 1-2).

If the enable/disable switch is opened the drive will decelerate to stop at which time the display will show STOP. If the potentiometer is turned to zero with the enable/disable closed the display will show H 0.0 (0.0Hz), if left like this for 20 seconds the drive will go into standby mode, display shows Stndby, waiting for a speed reference signal.









6.3. KEYPAD CONTROL

To allow the Fenner drive to be controlled from the keypad in a forward direction only, set P-12 =1:





1. Connect Motor as for terminal control above.
2. Enable the drive by closing the switch between control terminals 1 & 2. The display will show STOP.
3. Press the  key. The display shows H 0.0.
4. Press  to increase speed.
5. The drive will run forward, increasing speed until  is released.



The rate of acceleration is controlled by the setting of P-03, check this before starting.

6. Press  to decrease speed. The drive will decrease speed until  is released. The rate of deceleration is limited by the setting in P-04
7. Press the  key. The drive will decelerate to rest at the rate set in P-04.
8. The display will finally show STOP at which point the drive is disabled
9. To preset a target speed prior to enable, press the  key whilst the drive is stopped. The display will show the target speed, use the  &  keys to adjust as required then press the  key to return the display to STOP.
10. Pressing the  key will start the drive accelerating to the target speed.

To allow the Fenner drive to be controlled from the keypad in a forward and reverse direction, set P-12 =2:

11. Operation is the same as when P-12=1 for start, stop and changing speed.
12. Press the  key. The display changes to H 0.0.
13. Press  to increase speed
14. The drive will run forward, increasing speed until  is released. Acceleration is limited by the setting in P-03. The maximum speed is the speed set in P-01.
15. To reverse the direction of rotation of the motor, press the  key again.

7. PARAMETERS

7.1. STANDARD PARAMETERS

Par.	Description	Range	Default	Explanation
P-01	Maximum speed	P-02 to 5*P-09 (max 500Hz)	50Hz (60Hz)	Maximum speed limit – Hz or rpm. See P-10
P-02	Minimum speed	0 to P-01 (max 500Hz)	0Hz	Minimum speed limit – Hz or rpm. See P-10
P-03	Acceleration ramp time	0 to 600s	5s	Acceleration ramp time from 0 to base speed (P-09) in seconds
P-04	Deceleration ramp time	0 to 600s	5s	Deceleration ramp time from base speed (P-09) to standstill in seconds. When P-04=0, the deceleration ramp is set by P-24. Setting P-04=0 also activates dynamic ramp control, where the ramp may be extended automatically to prevent an O-Volt trip.
P-05	Stop mode select	0 : Ramp stop (brown-out ride-through) 1 : Coast to stop 2 : Ramp to stop (fast stop)	0	If the supply is lost and P-05=0 then the drive will try to continue running by reducing the speed of the load using the load as a generator. If P-05 = 2, the drive will ramp to stop using the P-24 decel ramp with dynamic brake control when mains supply lost.
P-06	Energy Optimiser	0: Disabled 1: Enabled	0	When enabled, automatically reduces applied motor voltage on light load. Minimum value is 50% of nominal.
P-07	Motor rated voltage	0, 20V to 250V 0, 20V to 500V	230V 400V (460V)	Rated (nameplate) voltage of the motor (Volts). Value limited to 250V for low voltage drives. Setting to zero disables voltage compensation
P-08	Motor rated current	25% -100% of drive rated current	Drive rating	Rated (nameplate) current of the motor (Amps).
P-09	Motor rated frequency	25Hz to 500Hz	50Hz (60Hz)	Rated (nameplate) frequency of the motor.
P-10	Motor rated speed	0 to 30 000 rpm	0	When non-zero, all speed related parameters are displayed in rpm
P-11	Voltage boost	Size 1: 0.0 to 20.0% Size 2: 0.0 to 15.0% Size 3: 0.0 to 10.0% of max output voltage.	Motor power dependent	Applies an adjustable boost to the Fenner drive voltage output at low speed to assist with starting 'sticky' loads. For continuous applications at low speed use a forced ventilated motor.
P-12	Terminal / Keypad / MODBUS / PI Drive Control Mode Selection	0.Terminal control 1. Keypad control – fwd only 2. Keypad control - fwd and rev 3. MODBUS network control with internal accel / decel ramps 4. MODBUS network control with accel / decel ramp adjustment 5. User PI control 6. User PI control with analog input 1 summation	0	Primary Control Mode of the drive. 0. Terminal control 1. Uni-directional keypad control. Keypad START button does not reverse direction. 2. Bi-directional keypad control. Keypad START button toggles between forward and reverse. 3. Control via Modbus RTU (RS485) comms interface using the internal accel / decel ramps 4. Control via Modbus RTU (RS485) comms nterface with accel / decel ramps updated via Modbus 5. User PI control with external feedback signal 6. User PI control with external feedback signal and summation with analog input 1
P-13	Trip log	Last four trips stored	Read only	Previous 4 trips stored in order of occurrence, with the most recent first. Press UP or DOWN to step through all four. The most recent trip is always displayed first. UV trip is only stored once. Further fault event logging functions are available through parameter group zero.
P-14	Extended menu access	Code 0 to 9 999	0	Set to "101" (default) for extended menu access. Change code in P-39 to prevent unauthorised access to the Extended Parameter Set

NOTE Default parameter values for Horse POver rated drives are shown in brackets
Standby mode is enabled automatically when the drive is at zero speed for > 20 seconds

7.2. EXTENDED PARAMETERS

Par.	Description	Range	Default	Explanation
P-15	Digital input function selec	0 to 12	0	Defines the function of the digital inputs depending on the control mode setting in P-12. See section 8 Analog and Digital Input Configurations for more information.
P-16	Analog input format	0..10V, b 0..10V, 0..20mA, t 4..20mA, r 4..20mA, t 20..4mA r 20..4mA	0..10V	Configures the voltage or current format of the analog input signal. b 0..10V can be used for bipolar input signals. A 50% offset can be applied to P-39 and 200% scaling in P-35 gives ± P-01 "t" indicates the drive will trip if signal removed when drive is enabled. "r" indicates the drive will ramp to Preset Speed 1 if signal is removed when drive is enabled
P-17	Effective switching frequency	4 .. 32kHz	8 / 16kHz	Sets maximum effective switching frequency of drive. If "rEd" is displayed, the switching frequency has been reduced to the level in P00-14 due to excessive drive heatsink temperature.
P-18	User relay output select	0 : Drive enabled 1 : Drive healthy 2 : Motor at target speed 3 : Drive tripped 4 : Motor speed >= limit 5 : Motor current >= limit 6 : Motor speed < limit 7 : Motor current < limit	1	Defines the function of the user relay, when the operating conditions are met. Disabled : Contacts open Enabled : Contacts closed Options 4 to 7: the Relay output is enabled using the level set in P-19
P-19	User relay output limit	0.0 to 100% for speed 0.0 to 200% for current	100%	Sets the limit for P-18 & P-25
P-20	Preset speed 1	-P-01 to P-01	0 Hz	Sets jog / preset speed 1
P-21	Preset speed 2	-P-01 to P-01	0 Hz	Sets jog / preset speed 2
P-22	Preset speed 3	-P-01 to P-01	0 Hz	Sets jog / preset speed 3
P-23	Preset speed 4	-P-01 to P-01	0 Hz	Sets jog / preset speed 4
P-24	2nd decel ramp time (Fast Stop)	0...25.0s	0	2nd Deceleration ramp time from base speed (P-09) to standstill in seconds. Selected using fast stop function via digital input setting or on mains loss as set by P-05 If set to zero drive will coast to STOP.
P-25	Analog output function select	Digital output mode 0 : Drive enabled 1 : Drive healthy 2 : Motor at target speed 3 : Drive tripped 4 : Motor speed >= limit 5 : Motor current >= limit 6 : Motor speed < limit 7 : Motor current < limit Analog output mode 8 : Motor speed 9 : Motor current	8	Digital Output Mode Options 0 to 7 select a digital voltage output signal Disabled : 0V Enabled : +24V, (20mA limit) Options 4 to 7 : the Digital output is enabled using the level set in P-19 Analog Output Mode Option 8 : Motor Speed signal range 0..10V = 0..100% of P-01 Option 9 : Motor Current signal range 0..10V = 0..200% of P-08
P-26	Skip frequency hysteresis band	0 to P-01	0 Hz	Set P-09 before adjusting. Speed reference held at upper or lower skip frequency limit until input signal reaches the opposite skip frequency limit. Speed ramps through the skip frequency band at a rate set by P-03 and P-04.
P-27	Skip frequency	P-02 to P-01	0 Hz	Set P-09 before adjusting. Skip frequency centre point
P-28	V/F characteristic adjustment voltage	0 ... P-07	0	Adjusts the applied motor voltage to this value at the frequency set in P-29
P-29	V/F characteristic frequency adjust	0 ... P-09	0.0Hz	Sets the frequency at which the adjustment voltage set in P-28 is applied Edge-r : if drive is powered up with Digital Input 1 closed (enabled), drive will not run. The switch must be opened & closed after power up or after clearing a trip for the drive to run.
P-30	Terminal mode restart function	EdgE-r, Auto-0 .. Auto-5	Auto-0	Auto-0 : drive will run whenever digital input 1 is closed (if not tripped). Auto-1..5 : drive will make 1..5 attempts to automatically restart after a trip (25s between attempts). If fault has cleared drive will restart. To reset the counter the Drive must be powered down, reset on the keypad or by re-enabling the drive.

P-31	Keypad mode restart function	0 : Minimum speed 1 : Previous speed 2 : Minimum speed (Auto-run) 3 : Previous speed (Auto-run)	1	If set to 0 or 2, drive will always start from minimum speed. If set to 1 or 3, drive ramps up to the operating speed prior to the last STOP command. If set to 2 or 3, the status of digital input 1 controls drive to start or stop. The start and stop button on the drive will not function in this case.
P-32	DC injection on stop	0 to 25.0s (disabled)	0	When > 0, DC injection braking activated when speed reaches zero with stop signal applied. Only applied on disable (Stop), not on enable. Uses the level set in P-11.
P-33	Spin Start (S2 & S3 only) DC injection on start (S1)	0 : Disabled 1 : Enabled	0	When enabled, drive starts from detected motor rotor speed. Short start delay possible if rotor stationary. Recommended for high inertia load applications. For Size 1 drives, P-33 = 1 enables DC injection braking on enable. The duration and levels are set by P-32 and P-11 respectively.
P-34	Brake chopper enable (not S1)	0 : Disabled 1 : Enabled with s/w protection 2 : Enabled without s/w protection	0	Software protection for Fenner standard brake resistors (200W). For Non-Fenner approved resistors and higher braking applications set to 2.
P-35	Analog input scaling	0 ... 500.0%	100%	Analog input scaling, resolution 0.1%.
	Serial Communications address	Adr : 0 disable, 1..63	1	Adr : Unique drive address for communication network When set to OP-buS, MODBUS disabled.
	MODBUS enable / baudrate select	OP-buS (fixed at 115.2 kbps) 9.6k to 115.2kbps (Modbus)	OP-buS	Communication with PDA, PC and Qport E2 possible
P-36	Trip enable / delay	0 (no trip) t 30, 100, 1000, 3000 (ms) r 30, 100, 1000, 3000 (ms)	t 3000 (3 second trip)	Setting a baudrate enables MODBUS at that baudrate and disables OP-buS. The time before a trip in the event of a communication loss can be set in milliseconds. Setting "0" disables the communications trip. "t" indicates the drive will trip if time exceeded. "r" indicates the drive will ramp to stop if time exceeded.
P-37	Access code definition	0 to 9 999	101	Defines Extended Parameter Set access code, P-14
P-38	Parameter access lock	0: Parameters can be changed & automatically saved on power down 1: Read-only. No changes allowed.	0	Controls user access to parameters. When P-38 = 0, all parameters can be changed and will be stored automatically. When P-38 = 1, parameters are locked and cannot be changed.
P-39	Analog input offset	-500.0 ... 500.0%	0%	Introduces an offset to the analog input level with a resolution 0.1%. e.g. 10% = 1V = 0Hz
P-40	Display speed scaling factor	0.000 to 6.000		Custom scaling factor applied to drive speed. If P-10 = 0, speed in Hz scaled by this factor. If P-10 > 0, speed in RPM scaled. Displayed as real-time variable on the drive display, indicated by a "c".
P-41	User PI Proportional Gain	0.0 ... 30.0	1.0	Higher value used for high inertia. Too high a value gives instability.
P-42	User PI Integral time constant	0.0s ... 30.0s	1.0s	Higher value gives slower, more damped response.
P-43	User PI operating mode	0: Direct 1: Inverse	0	If an increasing feedback signal should increase the speed of the motor, set to 'Inverse' mode.
P-44	User PI reference select	0: Digital 1: Analog	0	Sets the source for the PI control reference signal. When set to 1, analog input 1 is used.
P-45	User PI digital reference	0 ... 100%	0.0 %	Sets the preset reference used when P-44 = 0.
P-46	User PI feedback select	0 : 2nd analog input (T4) 1 : 1st analog input (T6) 2 : motor load current	0	This parameter selects the feedback signal source.
P-47	2nd analog input format	0..10V, 0..20mA, t 4..20mA, r 4..20mA, t 20..4mA r 20..4mA	0 ..10V	Selects the format of the 2nd analog input. "t" indicates the drive will trip if signal removed when drive is enabled. "r" indicates the drive will ramp to Preset Speed 1 if signal is removed when the drive is enabled

ADJUSTING THE VOLTAGE / FREQUENCY (V/f) CHARACTERISTICS

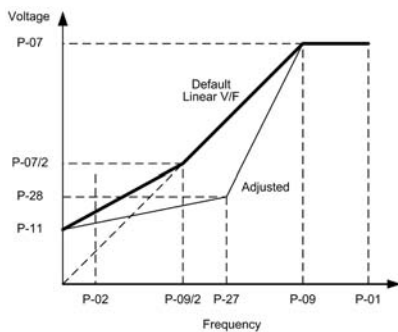

The V/f characteristic is defined by several parameters as shown. Reducing the voltage at a particular frequency reduces the current in the motor and hence the torque and power. The V/f curve can be further modified by using P-28 and P-29, where P-28 determines the percentage increase or decrease of the voltage applied to the motor at the frequency specified in P-29. This can be useful if motor instability is experienced at certain frequencies, if this is the case increase or decrease the voltage (P-28) at the speed of instability (P-29).

For applications requiring energy saving, typically HVAC and pumping, the energy optimiser (P-06) parameter can be enabled. This automatically reduces the applied motor voltage on light load.

P-00 READ ONLY DRIVE STATUS PARAMETERS

	Description	Display range	Explanation
P00-01	1st Analog input value	0 ... 100%	100% = max input voltage
P00-02	2nd Analog input value	0 ... 100%	100% = max input voltage
P00-03	Speed reference input	-P1-01 ... P1-01	Displayed in Hz if P-10 = 0, otherwise displayed in RPM
P00-04	Digital input status	Binary value	Drive digital input status
P00-05	Reserved	0	Reserved
P00-06	Reserved	0	Reserved
P00-07	Applied motor voltage	0 ... 600V AC	Value of RMS voltage applied to motor
P00-08	DC bus voltage	0 ... 1000V dc	Internal DC bus voltage
P00-09	Internal Heatsink temperature	-20 ... 100 °C	Temperature of heatsink in °C
P00-10	Hours run meter	0 to 99 999 hours	Not affected by resetting factory default parameters
P00-11	Run time since last trip (1)	0 to 99 999 hours	Run-time clock stopped by drive disable (or trip), reset on next enable only if a trip occurred. Reset also on next enable after a power down.
P00-12	Run time since last trip (2)	0 to 99 999 hours	Run-time clock stopped by drive disable (or trip), reset on next enable only if a trip occurred (under-volts not considered a trip) – not reset by power down / power up cycling unless a trip occurred prior to power down
P00-13	Run time since last disable	0 to 99 999 hours	Run-time clock stopped on drive disable, value reset on next enable
P00-14	Drive Effective Switching Frequency	4 to 32 kHz	Actual drive effective output switching frequency. This value maybe lower than the selected frequency in P-17 if the drive is too hot. The drive will automatically reduce the switching frequency to prevent an over temperature trip and maintain operation.
P00-15	DC bus voltage log	0 ... 1000V	8 most recent values prior to trip, updated every 250ms
P00-16	Thermistor temperature log	-20 ... 120 °C	8 most recent values prior to trip, updated every 500ms
P00-17	Motor current	0 to 2x rated current	8 most recent values prior to trip, updated every 250ms
P00-18	Software ID, IO & motor ctrl	e.g. "1.00", "47AE"	Version number and checksum. "1" on LH side indicates I/O processor, "2" indicates motor control
P00-19	Drive serial number	000000 ... 999999 00-000 ... 99-999	Unique drive serial number e.g. 540102 / 32 / 005
P00-20	Drive identifier	Drive rating	Drive rating, drive type e.g. 0.37, 1 230,3P-out

7.2.1. PARAMETER GROUP ZERO ACCESS AND NAVIGATION

When P-14 = P-37, all P-00 parameters are visible. Default value is 101.

When the user scrolls to P-00, pressing will display "P00-HH", where HH represents the secondary number within P-00. (i.e. 1 to 20). The User can then scroll to the required P-00 parameter.

Pressing once more will then display the value of that particular group zero parameter.

For those parameters which have multiple values (e.g. software ID), pressing the and keys will display the different values within that parameter.

Pressing returns to the next level up. If is then pressed again (without pressing or) , the display changes to the next level up (main parameter level, i.e. P-00).

If or is pressed whilst on the lower level (e.g. P00-05) to change the P-00 index, pressing <NAVIGATE> quickly displays that parameter value.

8. ANALOG AND DIGITAL INPUT CONFIGURATIONS

8.1. TERMINAL MODE (P-12 =0)

P-15	Digital input 1 (T2)	Digital input 2 (T3)	Digital input 3 (T4)	Analog input (T6)	Comments
0	Open: Stop (disable) Closed: Run (enable)	Open : Forward run Closed : Reverse run	Open : Analog speed ref Closed : Preset speed 1	Analog input 1 reference	
1	Open: Stop (disable) Closed: Run (enable)	Open: Analog speed ref Closed:Preset speed 1/2	Open: Preset speed 1 Closed:Preset speed 2	Analog input 1 reference	
2	Open: Stop (disable) Closed: Run (enable)	Digital Input 2	Digital Input 3	Preset Speed	Open: Preset speeds 1-4 Closed:Max Speed(P-01) Analog input used as digital input Closed status: 8V < Vin < 30V
		Open	Open	Preset Speed 1	
		Closed	Open	Preset Speed 2	
		Open	Closed	Preset Speed 3	
		Closed	Closed	Preset Speed 4	
3 ¹⁾	Open: Stop (disable) Closed: Run (enable)	Open : Analog speed ref Closed : Preset speed 1	External trip input : Open: Trip, Closed: Run	Analog input 1 reference	Connect external thermistor type PT100 or similar to digital input 3
4	Open: Stop (disable) Closed: Run (enable)	Open : Analog input 1 Closed : Analog input 2	Analog input 2 reference	Analog input 1 reference	Switches between analog inputs 1 and 2
5	Open: Fwd Stop Closed: Fwd Run	Open: Reverse Stop Closed: Reverse Run	Open : Analog speed ref Closed : Preset speed 1	Analog input 1 reference	Closing digital inputs 1 and 2 together carries out a fast stop (P-24)
6 ¹⁾	Open: Stop (disable) Closed: Run (enable)	Open : Forward Closed : Reverse	External trip input : Open: Trip, Closed: Run	Analog input 1 reference	Connect external thermistor type PT100 or similar to digital input 3
7	Open: Stop (disable) Closed: Fwd Run (enable)	Open: Stop (disable) Closed: Rev Run (enable)	External trip input : Open: Trip, Closed: Run	Analog input 1 reference	Closing digital inputs 1 and 2 together carries out a fast stop (P-24)
8	Open: Stop (disable) Closed: Run (enable)	Open : Forward Closed : Reverse	Digital Input 3	Analog Input 1	Preset Speed
			Open	Open	Preset Speed 1
			Closed	Open	Preset Speed 2
			Open	Closed	Preset Speed 3
			Closed	Closed	Preset Speed 4
9	Open: Stop (disable) Closed: Forward Run (enable)	Open: Stop (disable) Closed: Reverse Run (enable)	Digital Input 3	Analog Input 1	Preset Speed
			Open	Open	Preset Speed 1
			Closed	Open	Preset Speed 2
			Open	Closed	Preset Speed 3
			Closed	Closed	Preset Speed 4
10	Normally Open (NO) Momentary close to run	Normally Closed (NC) Momentary open to stop	Open : Analog speed ref Closed:Preset speed 1	Analog input 1 reference	
11	Normally Open (NO) Momentary close to run	Normally Closed (NC) Momentary open to stop	Normally Open (NO) Momentary close to rev	Analog input 1 reference	Closing digital inputs 1 and 3 together carries out a fast stop (P-24)
12	Open: Stop (disable) Closed: Run (enable)	Open: Fast Stop (disable) Closed: Run (enable)	Open : Analog speed ref Closed : Preset speed 1	Analog input 1 reference	

NOTE Negative Preset Speeds will be inverted if Run Reverse selected.

TYPICAL APPLICATIONS

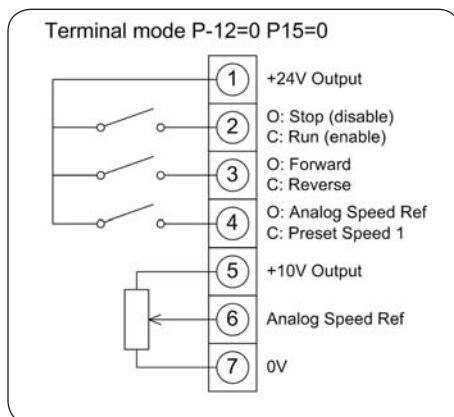

Analog speed input with 1 preset speed and fwd/rev switch

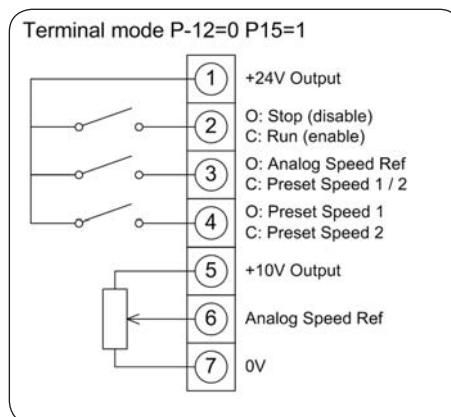

Analog speed input with 2 preset speeds

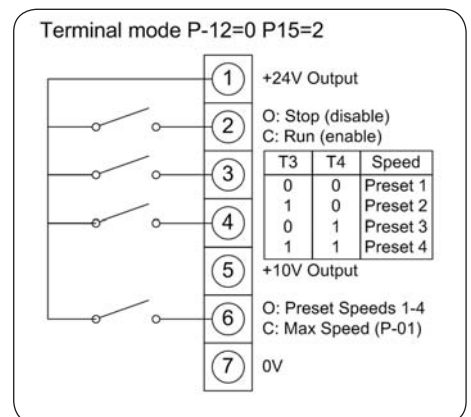

4 preset speeds and max speed select switch. Effectively giving 5 preset speeds

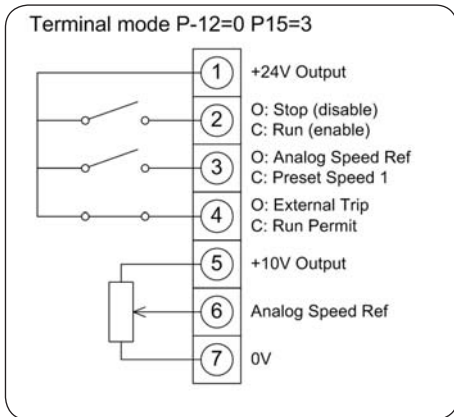

Analog speed input with 1 preset speed and motor thermistor trip

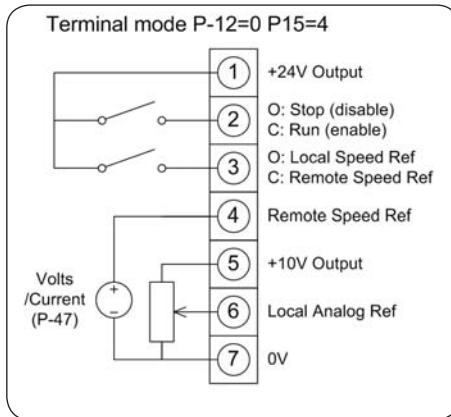

Local or remote analog speeds (2 analog inputs)

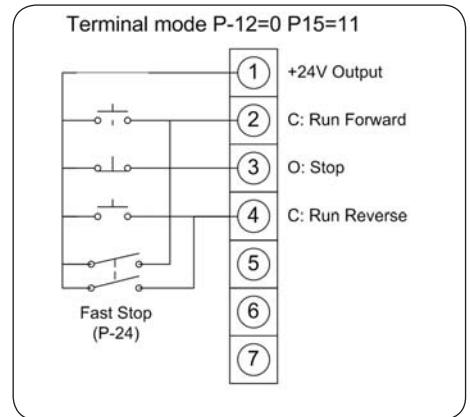

Push button fwd/rev/stop with fast stop using 2nd deceleration ramp

8.2. KEYPAD MODE (P-12 = 1 OR 2)

P-15	Digital input 1 (T2)	Digital input 2 (T3)	Digital input 3 (T4)	Analog input (T6)	Comments
0, 1, 5, 8..12	Open: Stop (disable) Closed: Run (enable)	Closed : remote UP push-button	Closed : remote DOWN push-button	Open : Forward +24V : Reverse	
2	Open: Stop (disable) Closed: Run (enable)	Closed : remote UP push-button	Closed : remote DOWN push-button	Open : Keypad speed ref +24V : Preset speed 1	
3 1)	Open: Stop (disable) Closed: Run (enable)	Closed : remote UP push-button	External trip input : Open: Trip, Closed: Run	Closed : remote DOWN push-button	Connect external thermistor type PT100 or similar to digital input 3
4	Open: Stop (disable) Closed: Run (enable)	Closed : remote UP push-button	Open : Keypad speed ref Closed : Analog input 1	Analog input 1	
6 1)	Open: Stop (disable) Closed: Run (enable)	Open : Forward run Closed : Reverse run	External trip input : Open: Trip, Closed: Run	Open : Keypad speed ref +24V : Preset speed 1	Connect external thermistor type PT100 or similar to digital input 3
7	Open: Forward Stop Closed: Forward Run	Open: Reverse Stop Closed: Reverse Run	External trip input : Open: Trip, Closed: Run	Open : Keypad speed ref +24V : Preset speed 1	Closing digital inputs 1 and 2 together carries out a fast stop (P-24)

EXAMPLE WIRING

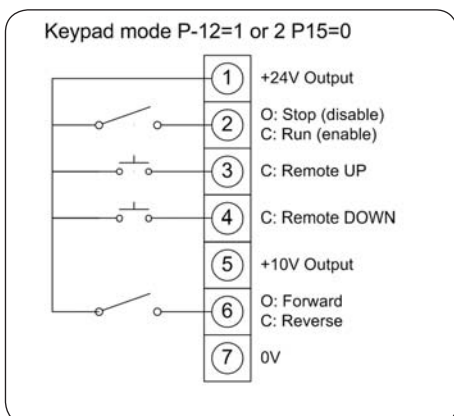

Remote push button speed control with fwd/rev

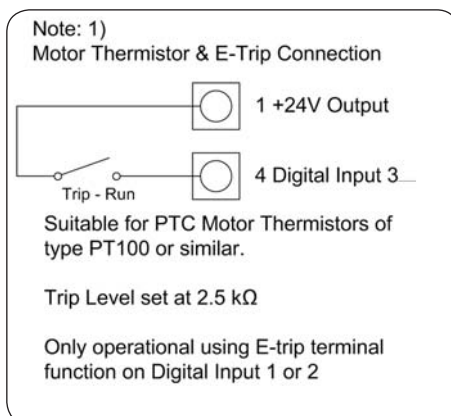

Analog speed input with 2 preset speeds

NOTE By default if the enable signal is present the drive will not Enable until the START button is pressed. To automatically enable the drive when the enable signal is present set P-31 = 2 or 3. This then disables the use of the START & STOP buttons

8.3. MODBUS CONTROL MODE (P12 = 3 OR 4)

P-15	Digital input 1 (T2)	Digital input 2 (T3)	Digital input 3 (T4)	Analog input (T6)	Comments
0..2, 4..5, 8..12	Open: Stop (disable) Closed: Run (enable)	No effect	No effect	No effect	Run and stop commands given via the RS485 link and Digital input 1 must be closed for the drive to run.
3 ¹⁾	Open: Stop (disable) Closed: Run (enable)	Open : Master speed ref Closed : Preset speed 1	External trip input : Open: Trip, Closed: Run	No effect	Connect external thermistor type PT100 or similar to digital input 3
6 ¹⁾	Open: Stop (disable) Closed: Run (enable)	Open : Master speed ref Closed : Analog input	External trip input : Open: Trip, Closed: Run	Analog input reference	Master Speed Ref - start and stop controlled via RS485. Keypad Speed Ref - drive auto runs if digital input 1 closed, depending on P-31 setting
7 ¹⁾	Open: Stop (disable) Closed: Run (enable)	Open : Master speed ref Closed : keypad speed ref	External trip input : Open: Trip, Closed: Run	No effect	

Further information the MODBUS RTU Register Map information and communication setup; please refer to the Advanced User Guide.

8.4. USER PI CONTROL MODE (P-12 = 5 OR 6)

P-15	Digital input 1 (T2)	Digital input 2 (T3)	Digital input 3 (T4)	Analog input (T6)	Comments
0, 2, 4..5, 8..12	Open: Stop (disable) Closed: Run (enable)	Open : PI control Closed : Preset speed 1	PI feedback analog input	No effect	
1	Open: Stop (disable) Closed: Run (enable)	Open : PI control Closed : Analog input 1	PI feedback analog input	Analog input 1	
3, 6, 7 ¹⁾	Open: Stop (disable) Closed: Run (enable)	Open : PI control Closed : Preset speed 1 similar to digital input 3	External trip input : Open: Trip, Closed: Run	PI feedback analog input	Connect external thermistor type PT100 or

EXAMPLE WIRING

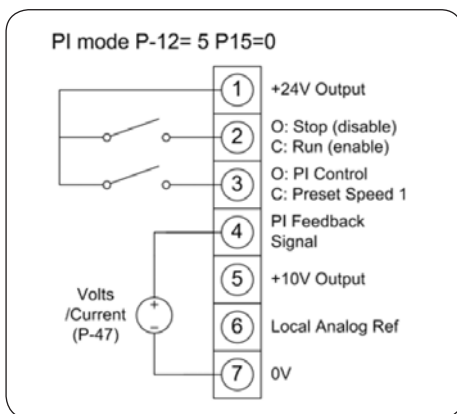

Remote closed loop PI feedback control with Local Preset speed 1

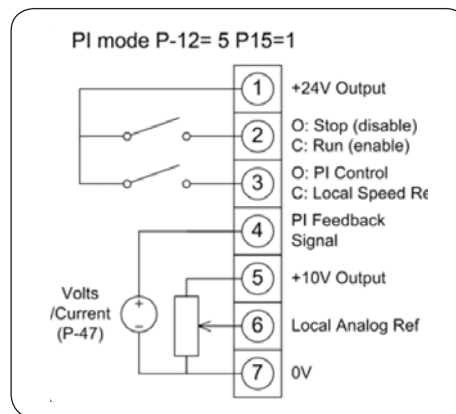

Remote closed loop PI feedback control with Local Analog speed input

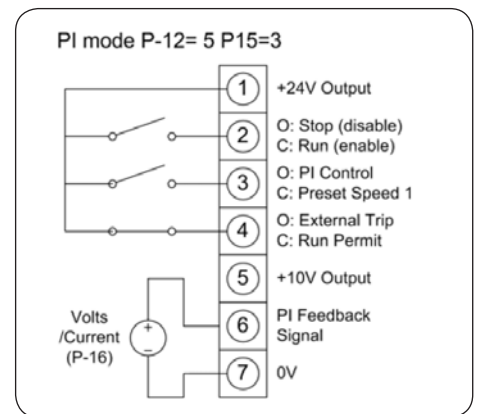

Remote closed loop PI feedback control with Local Preset speed 1 and motor thermistor trip

NOTE By default the PI reference is set for a digital reference level set in P-45. When using an Analog reference set P-44 = 1 (analog) and connect reference signal to analog input 1 (T6). The default settings for proportional gain (P-41), integral gain (P-42) and feedback mode (P-43) are suitable for most HVAC and pumping applications.

The analog reference used for PI controller can also be used as the local speed reference when P15=1.

Further information on configuring the PI controller for typical feedback applications; please refer to the Advanced User Guide.

9. TROUBLESHOOTING

9.1. FAULT MESSAGES

FAULT CODE	DESCRIPTION	CORRECTIVE ACTION
P-dEF	Factory Default parameters have been loaded	Press STOP key, drive is ready to configure for particular application
O-I	Over current on drive output. Excess load on the motor. Over temperature on the drive heatsink	Motor at constant speed: investigate overload or malfunction. Motor starting: load stalled or jammed. Check for star-delta motor wiring error. Motor accelerating/decelerating: The accel/decel time too short requiring too much power. If P-03 or P-04 cannot be increased, a bigger drive is required. Cable fault between drive and motor.
I. t-trP	Drive has tripped on overload after delivering >100% of value in P-08 for a period of time.	Check to see when the decimal points are flashing (drive in overload) and either increase acceleration ramp (P-03) or decrease motor load. Check cable length is within drive specification. Check the load mechanically to ensure it is free, and no jams, blockages or other mechanical faults exist
OI-b	Brake channel over current	Over current in the brake resistor circuit. Check the cabling to the brake resistor. Check the brake resistor value. Ensure minimum resistance values from the rating tables are observed.
OL-br	Brake resistor overload	Brake resistor overload. Increase deceleration time, reduce load inertia or add further brake resistors in parallel. Ensure minimum resistance values from the rating tables are observed.
PS-trp	Internal power stage fault	Check wiring to motor, look for ph-ph or ph-Earth short circuit. Check drive ambient temp, additional space or cooling needed? Check drive is not forced into overload.
O.Uolt	Over voltage on DC bus	Supply problem, or increase decel ramp time P-04.
U.Uolt	Under voltage on DC bus	This occurs routinely when power is switched off. If it occurs during running, check power supply voltage.
O-t	Heatsink over temperature	Check drive ambient temp. Additional space or cooling required.
U-t	Under temperature	Trip occurs when ambient temperature is less than -10°C. Temperature must be raised over -10°C in order to start the drive.
th-Flt	Faulty thermistor on heatsink.	Refer to your local Fenner authorised distributor.
E-triP	External trip (on digital Input 3)	E-trip requested on digital input 3. Normally closed contact has opened for some reason. If motor thermistor is connected check if the motor is too hot.
SC-trP	Comms loss trip	Check communication link between drive and external devices. Make sure each drive in the network has its unique address.
P-LOSS	Input phase loss trip	Drive intended for use with a 3 phase supply has lost one input phase.
SPIn-F	Spin start failed	Spin start function failed to detect the motor speed.
data-F	Internal memory fault.	Parameters not saved, defaults reloaded. Try again. If problem recurs, refer to your local Fenner authorised distributor.
4-20 F	Analog input current out of range	Check input current in range defined by P-16.
SC-Flt	Internal drive Fault	Refer to your local Fenner authorised distributor.
FAULTY	Internal drive Fault	Refer to your local Fenner authorised distributor.

10. TECHNICAL DATA

10.1. ENVIRONMENTAL

Operational ambient temperature range: 0 ... 50°C (frost and condensation free)

Storage ambient temperature range: -40 ... 60°C

Maximum altitude: 2000m. Derate above 1000m : 1% / 100m

Maximum humidity: 95%, non-condensing

10.2. RATING TABLES

200-240V ±10% - 1 Phase Input – 3 Phase Output

kW	HP	Frame Size	Nominal Input Current	Input MCB (type B)	Supply Cable Size	Nominal Output Current	150% Output Current 60secs	Motor Cable Size	Max Motor Cable Length	Min Brake Res Value
			Amps	Amps	mm2	Amps	Amps	mm2	m	Ω
0.37	0.5	1	6.7	6	1.5	2.3	3.45	1.5	25	-
0.75	1	1	12.5	10	1.5	4.3	6.45	1.5	25	-
1.5	2	1	19.3	20	4	7	10.5	1.5	25	-
1.5	2	2	19.3	20	4	7	10.5	1.5	100	47
2.2	3	2	28.8	32(35)*	4	10.5	15.75	1.5	100	47

200-240V ±10% - 3 Phase Input – 3 Phase Output

kW	HP	Frame Size	Nominal Input Current	Input MCB (type B)	Supply Cable Size	Nominal Output Current	150% Output Current 60secs	Motor Cable Size	Max Motor Cable Length	Min Brake Res Value
			Amps	Amps	mm2	Amps	Amps	mm2	m	Ω
0.37	0.5	1	3	6	1.5	2.3	3.45	1.5	25	-
0.75	1	1	5.8	10	1.5	4.3	6.45	1.5	25	-
1.5	2	1	9.2	16(15)*	2.5	7	10.5	1.5	25	-
1.5	2	2	9.2	16(15)*	2.5	7	10.5	1.5	100	47
2.2	3	2	13.7	20	4	10.5	15.75	1.5	100	47
4.0	5	3	20.7	32(35)*	4	18	27	2.5	100	47

380-480V ±10% - 3 Phase Input – 3 Phase Output

kW	HP	Frame Size	Nominal Input Current	Input MCB (type B)	Supply Cable Size	Nominal Output Current	150% Output Current 60secs	Motor Cable Size	Max Motor Cable Length	Min Brake Res Value
			Amps	Amps	mm2	Amps	Amps	mm2	m	Ω
0.75	1	1	2.9	5	1.5	2.2	3.3	1.5	25	-
1.5	2	1	5.4	10	1.5	4.1	6.15	1.5	25	-
1.5	2	2	5.4	10	1.5	4.1	6.15	1.5	50	100
2.2	3	2	7.6	10	1.5	5.8	8.7	1.5	50	100
4	5	2	12.4	16(15)*	2.5	9.5	14.25	1.5	50	100
5.5	7.5	3	17.6	20	4	14	21	2.5	100	22
7.5	10	3	22.1	25	4	18	27	2.5	100	22
11	15	3	28.2	32(35)*	6	24	36	4	100	22

Output Frequency range: 0 - P-01 (500Hz max)

For UL compliance Motor Cable to be Copper 75C and Fuse current rating defined by ratings marked () *

10.3. MAXIMUM SUPPLY RATINGS FOR UL COMPLIANCE:

Drive rating	Maximum supply voltage	Maximum supply short-circuit current
230V ratings – 0.37kW (0.5HP) to 3.7kW (5HP)	240V rms (AC)	5kA rms (AC)
400/460V ratings – 0.75kW(1HP) to 7.5kW(10HP)	480V rms (AC)	5kA rms (AC)

All the drives in the above table are suitable for use on a circuit capable of delivering not more than the above specified maximum short-circuit Amperes symmetrical with the specified maximum supply voltage.

Fenner® QD:E EASY START-UP GUIDE

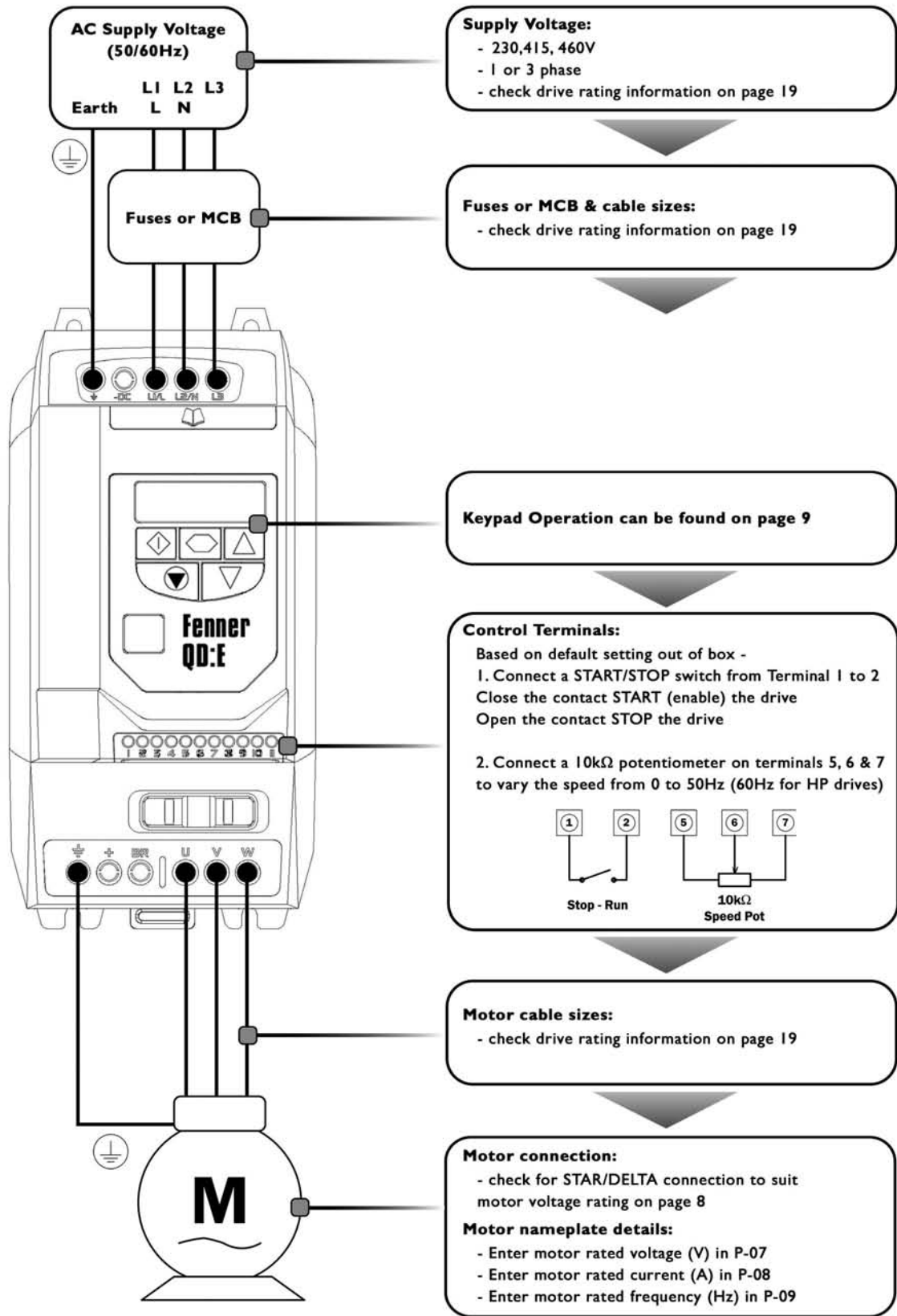

82-E2MAN-FN



82-I55E2-FN